



1943-2022
XCMG 79 年

XCMG

CONSTRUCTION HOIST 施工升降机

SC200/200ES1

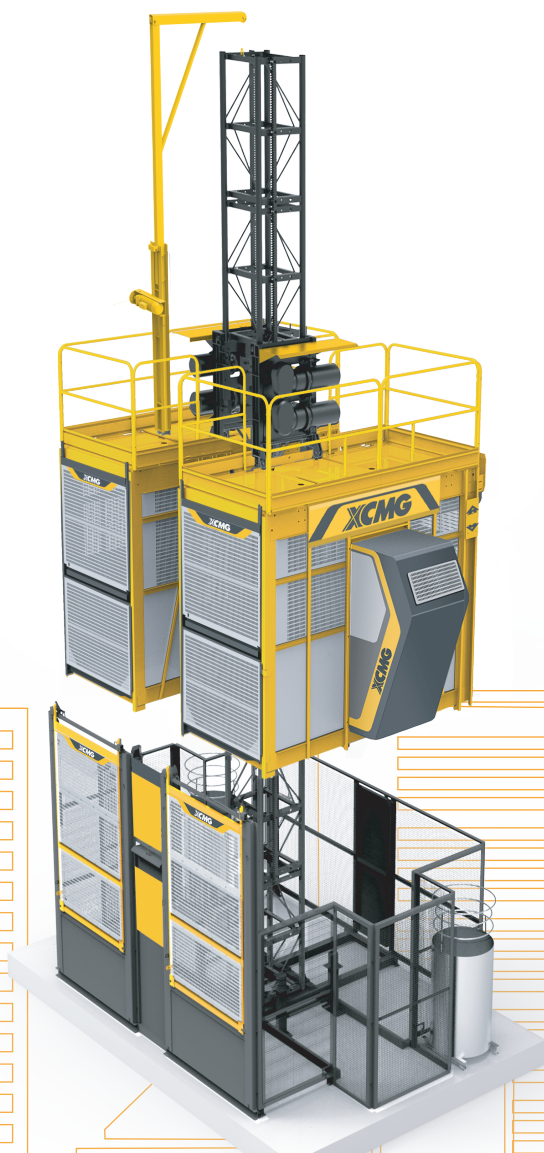

出口款变频施工升降机

Export variable frequency convertible hoist

- 整机工业化设计，广泛采用冲孔铝板，外观新颖，高端大气；
 - 吊笼、底笼等主要结构件轻量化设计，采用高强度钢，强度更高，安全性更好；
 - 底笼采用快速安拆技术，单人安拆，方便快捷；
 - 结构件模块化设计，通用性高，维保便捷；
 - 传动机构采用齿轮减速机，传动效率高，绿色节能；
 - 电气采用变频控制，操作简单，运行平稳，安全可靠。
- The industrial design of the whole machine, is widely used perforated aluminum plates, with novel, high-end and elegant appearance;
 - The main structural parts such as the elevator cage and the bottom cage applies lightweight design;
 - The bottom cage applies quick installation and disassembly technology. Only one person can install and disassemble, which is very convenient and easy;
 - The structural parts apply modular design, which is versatile and convenient to maintain;
 - The transmission mechanism uses a gear reducer, which has high transmission efficiency and is green and energy saving;
 - The frequency conversion control is used for the electrical devices, with simple control and stable operation, which is safe and reliable.

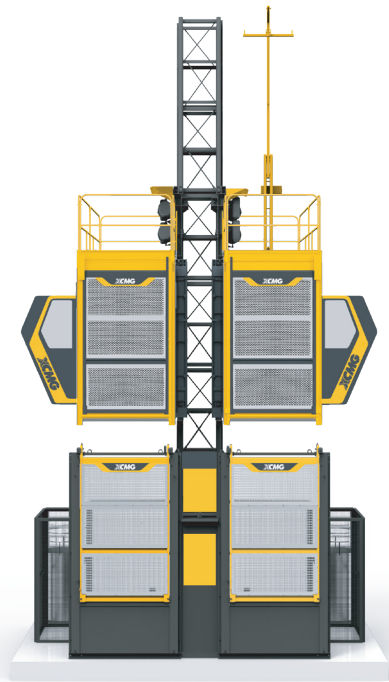

吊笼内空尺寸 Inside size of the cage

长L 宽W 高H
3200 × **1500** × **2200**
 mm mm mm



技术参数表 Technical data

产品型号 Model	额定载重量 (Kg) Rated load	提升速度 (m/min) Lifting speed	标配高度 (m) Height	附着间距 (m) Attachmentspace	电机功率 (KW) Motor power	变频器功率 (KW) Inverter power	防坠器型号 Safety device
双笼 Twin cage SC200/200ES1	2×2000	0~50	60	9	2×2×11/18.5	2×37	SAJ40-1.2

备注:

- 标准节规格为650×650×1508mm;
- 标准配置: 电缆滑车、调节范围为3-3.6m附墙、喷粉标准节、人脸识别、自动平层、故障自诊断、电动吊杆、楼层呼叫器等。
- 可选配置: 滑触线、热浸锌标准节。
- 吊笼尺寸、附墙调节范围可非标定制。

Remark:

- The specification of mast is 650×650×1508mm;
- Standard Configuration: Cable trolley, anchorage frame adjustment range is 3-3.6m, powder spraying type mast sections, Face recognition, automatic leveling, fault self-diagnosis, electric boom, floor pagers, etc.
- Optional Configuration: Sliding contact line, hot-dip galvanized type mast sections.
- The size of the lifting cage and the adjustment range of the attached wall can be customized.